

EE 508

Lecture 20

Sensitivity Functions

- Comparison of Filter Structures
- Performance Prediction

Review from last time

Effects of GB on poles of KRC and -KRC Lowpass Filters

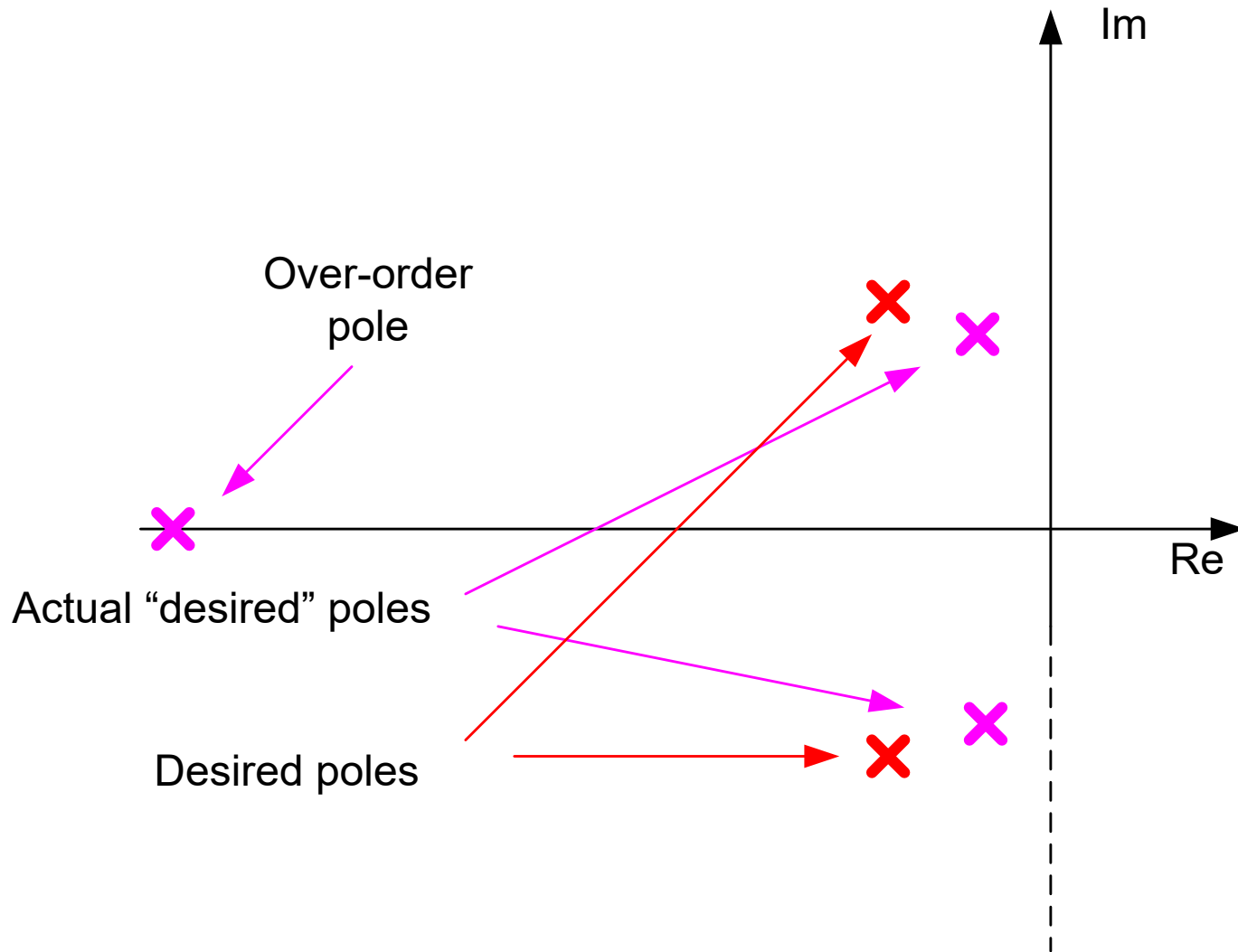

Review from last time

GB effects in KRC and -KRC Lowpass Filter

$$T(s) = \frac{K_0 \omega_0^2}{s^2 + s \left[\frac{\omega_0}{Q} \right] + \omega_0^2 + K_0 \tau s \left(s^2 + s \left[\frac{\omega_0}{Q} \left(1 + K_0 Q \sqrt{\frac{R_1 C_1}{R_2 C_2}} \right) \right] + \omega_0^2 \right)}$$

$$T(s) = -K_0 \frac{1}{R_1 R_2 C_1 C_2} \left(s^2 + s \left[\frac{1}{R_1 C_1} \left(1 + \frac{R_1}{R_3} \right) + \frac{1}{R_4 C_2} + \frac{1}{R_2 C_2} \left(1 + \frac{C_2}{C_1} \right) \right] + \left[\frac{1 + (R_1/R_3)(1+K_0) + (R_1/R_4)(1 + (R_2/R_3) + (R_2/R_1))}{R_1 R_2 C_1 C_2} \right] \right)$$

$$+ \tau s (1+K_0) \left(s^2 + s \left[\frac{1}{R_1 C_1} \left(1 + \frac{R_1}{R_3} \right) + \frac{1}{R_4 C_2} + \frac{1}{R_2 C_2} \left(1 + \frac{C_2}{C_1} \right) \right] + \left[\frac{1 + (R_1/R_3) + (R_1/R_4)(1 + (R_2/R_3) + (R_2/R_1))}{R_1 R_2 C_1 C_2} \right] \right)$$

- Analytical expressions for ω_0 , Q , poles, zeros, and other key parameters are unwieldy in these circuits and as bad or worse in many other circuits (require solution of 3rd order polynomial!!)
- Sensitivity metrics give considerable insight into how filters perform and are widely used to assess relative performance
- Need sensitivity characterization of real numbers as well as complex quantities such as poles and zeros
- If sensitivity expressions are obtained for a given structure, it can be catalogued rather than recalculated
- Since analytical expressions for key parameters are unwieldy in even simple circuits, obtaining expressions for the purpose of calculating sensitivity appears to be a formidable task !**

Review from last time

Define the standard sensitivity function as

$$S_x^f = \frac{\partial f}{\partial x} \bullet \frac{x}{f}$$

S_x^f Is widely used except when x or f assume extreme values of 0 or ∞

Define the derivative sensitivity function as

$$D_x^f = \frac{\partial f}{\partial x}$$

D_x^f Is more useful when x or f ideally assume extreme values of 0 or ∞

Review from last time

$$\frac{dF}{F} = \sum_{i=1}^k \left(\boxed{S_{x_i}^f \mid \vec{X}_N} \cdot \boxed{\frac{dx_i}{x_{iN}}} \right)$$

Dependent only on components
(not circuit structure)

Dependent on circuit structure (for some
circuits, also not dependent on components)

**The sensitivity functions are thus useful for comparing
different circuit structures**

**The variability which is the product of the sensitivity
function and the normalized component differential is
more important for predicting circuit performance**

Variability Formulation

$$V_{x_i}^f = S_{x_i}^f \Big|_{\vec{X}_N} \bullet \frac{dx_i}{x_{iN}}$$

$$\frac{dF}{F} = \sum_{i=1}^k V_{x_i}^f \Big|_{\vec{X}_N}$$

Variability includes effects of both circuit structure and components on performance

If component variations are small, high sensitivities are acceptable

If component variations are large, low sensitivities are usually critical

Review from last time

Observation:

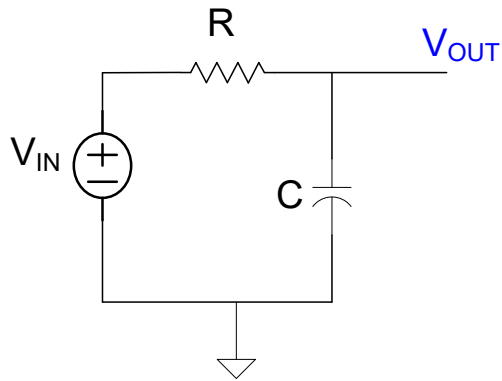

$$\omega_0 = 1/RC$$

$$S_R^{\omega_0} = -1$$

$$S_C^{\omega_0} = -1$$

$$\sum_{\text{All resistors}} S_{R_i}^{\omega_0} = -1$$

$$\sum_{\text{All capacitors}} S_{C_i}^{\omega_0} = -1$$

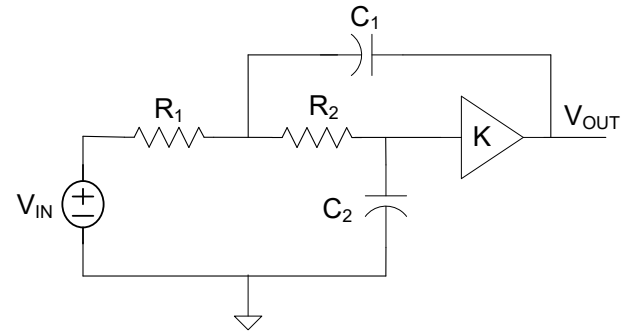

$$\omega_0 = \frac{1}{\sqrt{R_1 R_2 C_1 C_2}}$$

$$S_{R_1}^{\omega_0} = -1/2$$

$$S_{C_1}^{\omega_0} = -1/2$$

$$S_{R_2}^{\omega_0} = -1/2$$

$$S_{C_2}^{\omega_0} = -1/2$$

$$\sum_{\text{All resistors}} S_{R_i}^{\omega_0} = -1$$

$$\sum_{\text{All capacitors}} S_{C_i}^{\omega_0} = -1$$

At this stage, this is just an observation about summed sensitivities but later will establish some fundamental properties of summed sensitivities

Review from last time

$$\frac{dF}{F} = \sum_{i=1}^k \left(S_{x_i}^f \Big|_{\bar{X}_N} \bullet \frac{dx_i}{x_i} \right) + \frac{1}{F_N} \sum_{i=1}^{ky} \left(S_{y_i}^f \Big|_{\bar{Y}_N=0} \bullet y_i \right)$$

Low sensitivities in a circuit are often preferred but in some applications, low sensitivities would be totally unacceptable

Examples where low sensitivities are unacceptable are circuits where a characteristics F must be tunable or adjustable!

Some useful sensitivity theorems

$$S_x^{kf} = S_x^f$$

where k is a constant

$$S_x^{f^n} = n \bullet S_x^f$$

$$S_x^{1/f} = -S_x^f$$

$$S_x^{\sqrt{f}} = \frac{1}{2} S_x^f$$

$$S_x^{\prod_{i=1}^k f_i} = \sum_{i=1}^k S_x^{f_i}$$

Some useful sensitivity theorems (cont)

$$S_x^{f/g} = S_x^f - S_x^g$$

$$S_x^{\sum_{i=1}^k f_i} = \frac{\sum_{i=1}^k f_i S_x^{f_i}}{\sum_{i=1}^k f_i}$$

$$S_x^f = -S_x^{1/x}$$

Example:

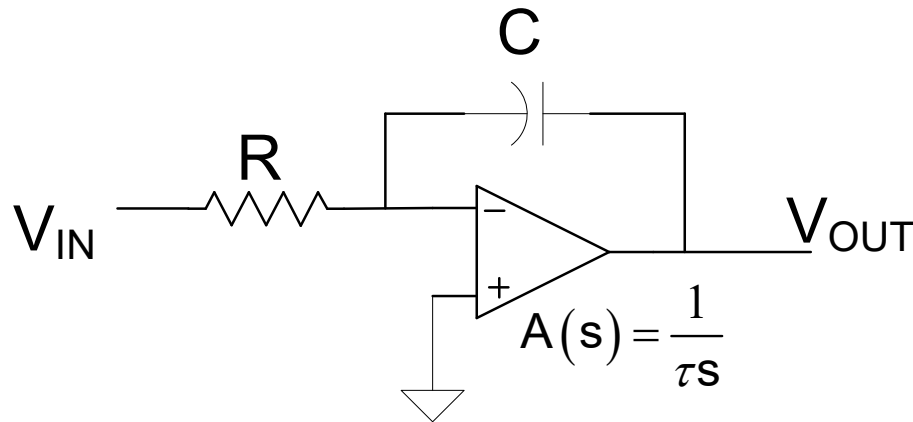

Ideally
$$I(s) = -\frac{1}{RCs} = -\frac{I_0}{s}$$
 I_0 termed the unity gain freq of integrator
$$I_0 = \frac{1}{RC}$$

I_0 is one of the most important parameters of an integrator used in a filter

Assume ideally $R=1K$, $C=3.18nF$ so that $I_0=50KHz$

Actually $GB=600KHz$, $R=1.05K$, and $C=3.3nF$

- Determine an approximation to the actual unity gain frequency using a sensitivity analysis
- Write an analytical expression for the actual unity gain frequency

Example:

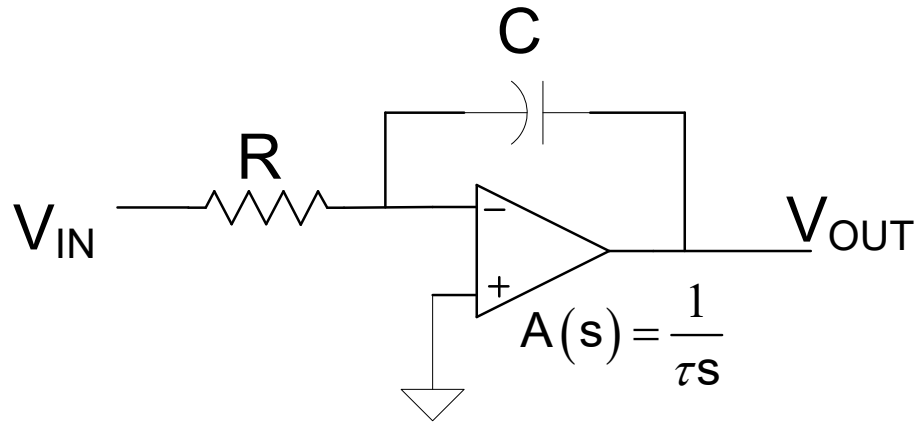

Assume ideally $R=1K$, $C=3.18nF$ so that $f_0=50KHz$

Actually $GB=600KHz$, $R=1.05K$, and $C=3.3nF$

Observe

$$\frac{\Delta R}{R} = \frac{.05K}{1K} = .05$$

$$\frac{\Delta C}{C} = \frac{.12nF}{3.18nF} = .038$$

$$\frac{f_0}{GB} = \tau f_0 = \frac{50KHz}{600KHz} = .083$$

Example:

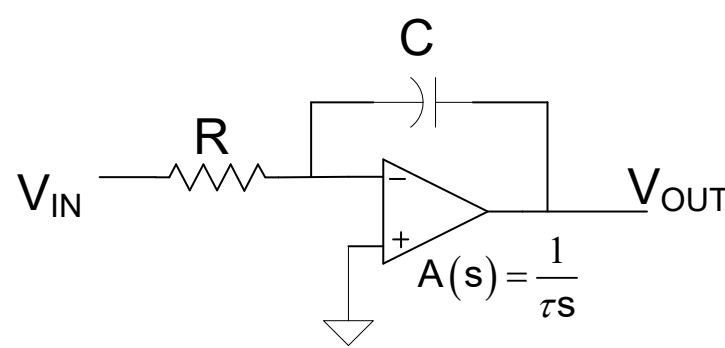

Ideally

$$I(s) = -\frac{1}{RCs} = -\frac{I_0}{s}$$

Solution:

Define I_{0A} to be the actual unity gain frequency

$$I_0 = \frac{1}{RC}$$

$$\frac{dF}{F} = \sum_{i=1}^k \left(S_{x_i}^f \Big|_{\bar{X}_N, \bar{Y}_N=0} \bullet \frac{dx_i}{x_i} \right) + \frac{1}{F_N} \sum_{i=1}^{k_y} \left(S_{y_i}^f \Big|_{\bar{X}_N, \bar{Y}_N=0} \bullet y_i \right)$$

$$\frac{dI_{0A}}{I_{0A}} = \left[S_R^{I_{0A}} \Big|_{R_N, C_N, \tau=0} \right] \frac{dR}{R_N} + \left[S_C^{I_{0A}} \Big|_{R_N, C_N, \tau=0} \right] \frac{dC}{C_N} + \frac{1}{I_{0N}} \left(S_{\tau}^{I_{0A}} \Big|_{\bar{X}_N, \bar{Y}_N=0} \bullet \tau \right)$$

$$S_R^{I_{0A}} \Big|_{R_N, C_N, \tau=0} = S_R^I \Big|_{R_N, C_N}$$

$$S_C^{I_{0A}} \Big|_{R_N, C_N, \tau=0} = S_C^I \Big|_{R_N, C_N}$$

$$S_R^I \Big|_{R_N, C_N} = -1$$

$$S_C^I \Big|_{R_N, C_N} = -1$$

It remains to calculate

$$S_{\tau}^{I_{0A}} \Big|_{\bar{X}_N, \bar{Y}_N=0}$$

Example:

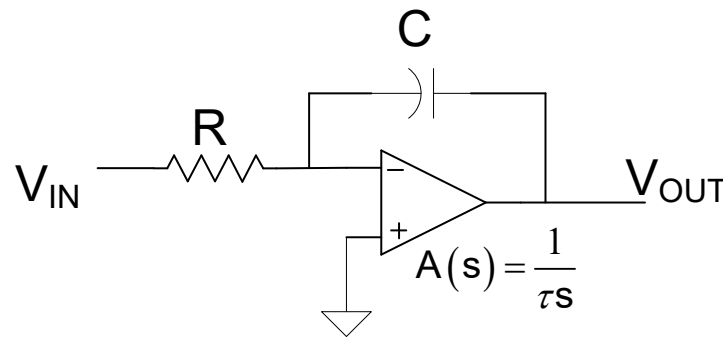

Ideally

$$I(s) = -\frac{1}{RCs} = -\frac{I_0}{s}$$

Solution:

Still need $\left. \frac{I_{0A}}{\tau} \right|_{\bar{X}_N, \bar{Y}_N=0}$

Define I_{0A} to be the actual unity gain frequency

$$I_A(s) = -\frac{1}{RCs + \tau s(1 + RCs)}$$

$$(RC)^2 \tau^2 I_{0A}^4 + I_{0A}^2 (RC + \tau)^2 = 1$$

$$I_A(j\omega) = -\frac{1}{-\tau RC \omega^2 + j(\omega RC + \tau \omega)}$$

$$\left. \frac{I_{0A}}{\tau} \right|_{\bar{X}_N, \bar{Y}_N=0} = ?$$

$$|I_A(j\omega)|^2 = \frac{1}{(RC)^2 \tau^2 \omega^4 + \omega^2 (RC + \tau)^2}$$

$$|I_A(j\omega)|^2 = \frac{1}{(RC)^2 \tau^2 \omega^4 + \omega^2 (RC + \tau)^2} = 1$$

$$\frac{1}{(RC)^2 \tau^2 I_{0A}^4 + I_{0A}^2 (RC + \tau)^2} = 1$$

Example:

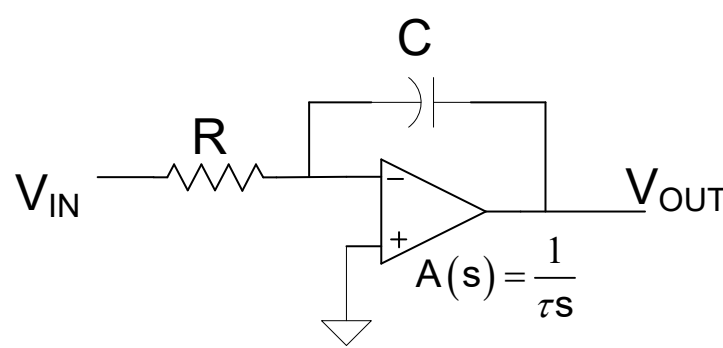

Ideally

$$I(s) = -\frac{1}{RCs} = -\frac{I_0}{s}$$

Solution:

Still need $\left. \frac{\partial I_{0A}}{\partial \tau} \right|_{\bar{X}_N, \bar{Y}_N=0}$ Define I_{0A} to be the actual unity gain frequency

$$(RC)^2 \tau^2 I_{0A}^4 + I_{0A}^2 (RC + \tau)^2 = 1$$

$$\left. \frac{\partial I_{0A}}{\partial \tau} \right|_{\bar{X}_N, \bar{Y}_N=0} = \left(\frac{\partial I_{0A}}{\partial \tau} \right) \Big|_{\bar{X}_N, \bar{Y}_N=0}$$

$$(RC)^2 \tau^2 4I_{0A}^3 \left(\frac{\partial I_{0A}}{\partial \tau} \right) + 2\tau (RC)^2 I_{0A}^4 + 2I_{0A} \left(\frac{\partial I_{0A}}{\partial \tau} \right) (RC + \tau)^2 + 2(RC + \tau) I_{0A}^2 = 0$$

Evaluating at $\bar{X}_N, \bar{Y}_N = 0$

$$2I_0^1 \left(\frac{\partial I_{0A}}{\partial \tau} \Big|_{\bar{X}_N, \bar{Y}_N=0} \right) (RC)^2 + 2(RC) I_0^2 = 0$$

$$\left(\frac{\partial I_{0A}}{\partial \tau} \Big|_{\bar{X}_N, \bar{Y}_N=0} \right) = \frac{-I_0}{RC} = \left. \frac{\partial I_{0A}}{\partial \tau} \right|_{\bar{X}_N, \bar{Y}_N=0} = -I_0^2$$

Example:

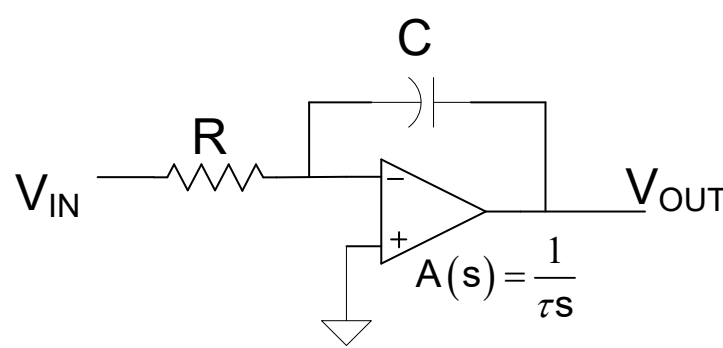

Ideally

$$I(s) = -\frac{1}{RCs} = -\frac{I_{ON}}{s}$$

Solution:

$$\frac{dI_{0A}}{I_{0A}} = \left[S_R^{I_{0A}} \Big|_{R_N, C_N, \tau=0} \right] \frac{dR}{R_N} + \left[S_C^{I_{0A}} \Big|_{R_N, C_N, \tau=0} \right] \frac{dC}{C_N} + \frac{1}{I_{ON}} \left(S_\tau^{I_{0A}} \Big|_{\bar{X}_N, \bar{Y}_N=0} \bullet \tau \right)$$

$$S_R^I \Big|_{R_N, C_N} = S_C^I \Big|_{R_N, C_N} = -1 \quad S_\tau^{I_{0A}} \Big|_{\bar{X}_N, \bar{Y}_N=0} = -I_{ON}^2$$

$$\frac{\Delta R}{R} = .05 \quad \frac{\Delta C}{C} = .038 \quad \tau I_0 = .083$$

$$\frac{dI_{0A}}{I_{0A}} = [-1] \cdot .05 + [-1] \cdot .038 + \frac{1}{I_{ON}} (-I_{ON}^2 \bullet \tau)$$

$$\frac{dI_{0A}}{I_{0A}} = [-1] \cdot .05 + [-1] \cdot .038 + (-.083)$$

$$\frac{dI_{0A}}{I_{0A}} = -.088 - .083$$

← Due to passives
← Due to actives

Example:

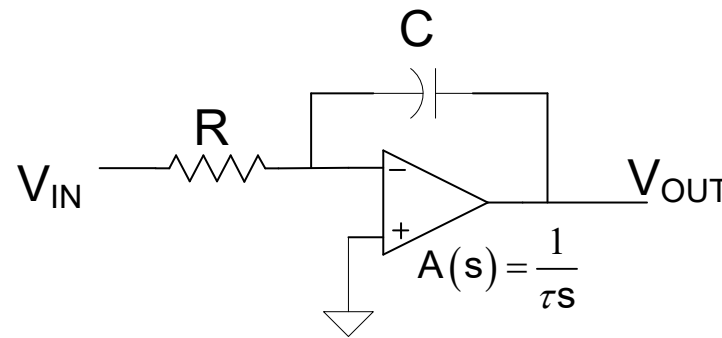

Ideally

$$I(s) = -\frac{1}{RCs} = -\frac{I_{ON}}{s}$$

Solution:

$$\frac{dI_{0A}}{I_{0A}} = -.171$$

$$I_{ON} = 50\text{KHz}$$

$$I_{0A} \cong 0.829 I_{ON} = 41.45\text{KHz}$$

Note that with the sensitivity analysis, it was not necessary to ever determine I_{0A} !!

a) Determine an approximation to the actual unity gain frequency using a sensitivity analysis

b) Write an analytical expression for the actual unity gain frequency

$$(RC)^2 \tau^2 I_{0A}^4 + I_{0A}^2 (RC + \tau)^2 = 1$$

Must solve this quadratic for I_{0A}

Solving, obtain $I_{0A} = 42.6\text{KHz}$

Note this is close to the value obtained with the sensitivity analysis

Although in this simple numerical example, it may have been easier to go directly to this expression, in more complicated circuits sensitivity analysis is much easier

Example:

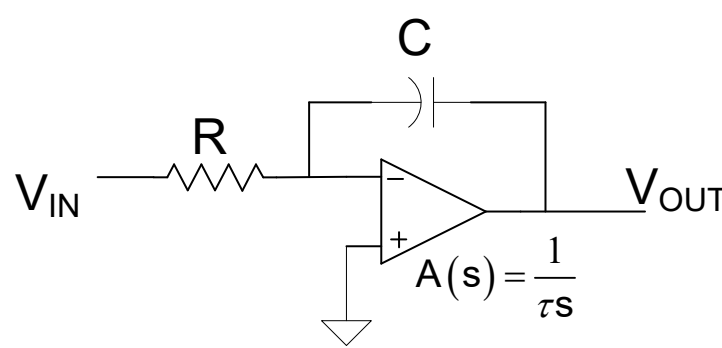

Ideally

$$I(s) = -\frac{1}{RCs} = -\frac{I_{ON}}{s}$$

$$(RC)^2 \tau^2 I_{OA}^4 + I_{OA}^2 (RC + \tau)^2 = 1$$

- Note that with the sensitivity analysis, it was not necessary to ever determine I_{OA} !!
- The sensitivity analysis was analytical, and only at the end was a numerical result obtained
- A parametric solution is usually necessary to compare different structures
- Though a closed-form analytical expression for I_{OA} could have been obtained for this simple circuit, closed-form solutions for parameters of interest often do not exist !
- Though the active sensitivity analysis was tedious, major simplifications for active sensitivity analysis will be discussed later.

How can sensitivity analysis be used to compare the performance of different circuits?

Circuits have many sensitivity functions

If two circuits have exactly the same number of sensitivity functions and all sensitivity functions in one circuit are lower than those in the other circuit, then the one with the lower sensitivities is a less sensitive circuit

But usually this does not happen !

Designers would like a single metric for comparing two circuits !

$$\frac{dF}{F} = \sum_{i=1}^k \left(\boxed{S_{x_i}^f |_{\bar{X}_N}} \cdot \boxed{\frac{dx_i}{x_{iN}}} \right)$$

Dependent on circuit structure
 (for some circuits, also not dependent
 on components)

Dependent only on components
 (not circuit structure)

Consider:

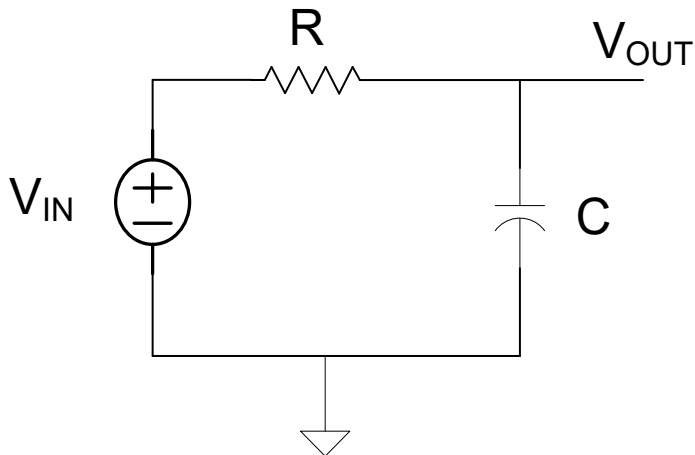

$$T(s) = \frac{1}{1+RCs}$$

$$T(s) = \frac{\omega_0}{s + \omega_0}$$

$$\omega_0 = \frac{1}{RC}$$

$$\omega_0 = \frac{1}{RC}$$

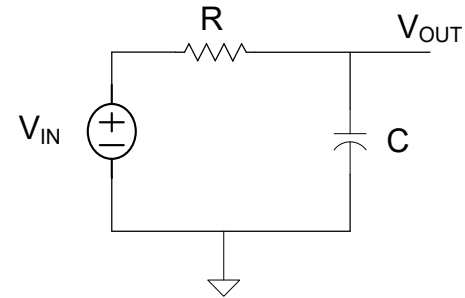

$$S_R^{\omega_0} = -1$$

$$S_C^{\omega_0} = -1$$

Dependent only on components
(not circuit structure)

$$\frac{d\omega_0}{\omega_0} = \sum_{i=1}^2 \left(S_{x_i}^{\omega_0} \Big|_{\vec{X}_N} \bullet \frac{dx_i}{x_{iN}} \right)$$

$$\frac{d\omega_0}{\omega_0} = [-1] \bullet \frac{dR}{R_N} + [-1] \bullet \frac{dC}{C_N}$$

Dependent only on circuit structure

$$\frac{dF}{F} = \sum_{i=1}^k \left(\boxed{S_{x_i}^f |_{\bar{X}_N}} \bullet \frac{\boxed{dx_i}}{x_{iN}} \right)$$

Dependent on circuit structure
 (for some circuits, also not dependent
 on components)

Dependent only on components
 (not circuit structure)

Consider now:

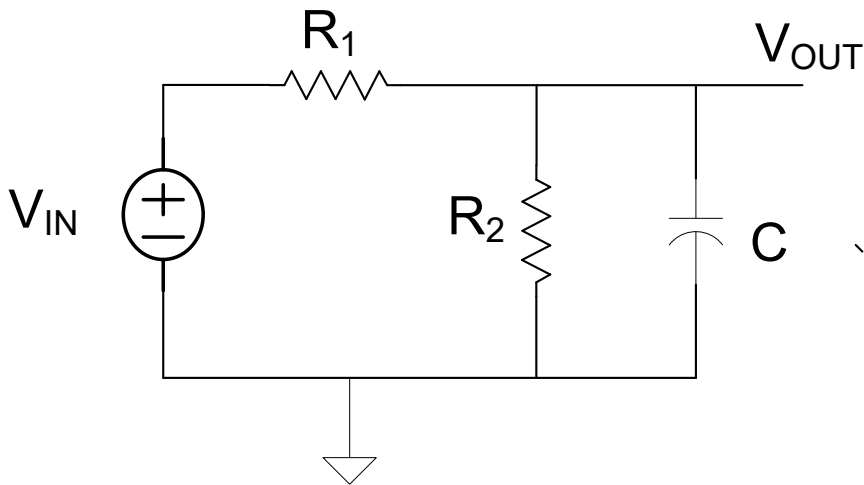

$$T(s) = \frac{\frac{R_2}{R_1+R_2}}{1 + \left(\frac{R_1 R_2}{R_1+R_2} C \right) s}$$

$$T(s) = \frac{R_2}{R_1+R_2} \bullet \frac{\omega_0}{s + \omega_0}$$

$$\omega_0 = \frac{R_1+R_2}{R_1 R_2 C}$$

$$S_{R_1}^{\omega_0} = ?$$

$$\omega_0 = \frac{R_1 + R_2}{R_1 R_2 C}$$

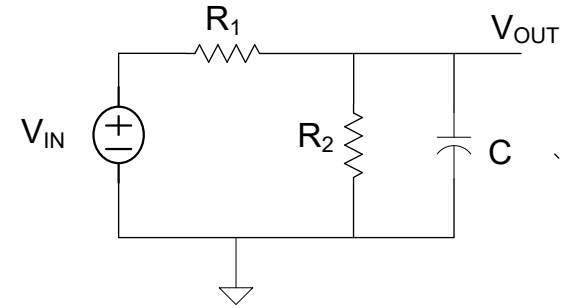

$$\omega_0 = \frac{G_1 + G_2}{C}$$

$$S_{R_1}^{\omega_0} = -S_{G_1}^{\omega_0}$$

$$S_{G_1}^{\omega_0} = S_{G_1 + G_2}$$

$$S_{G_1 + G_2}^{G_1} = \left(\frac{\partial (G_1 + G_2)}{\partial G_1} \right) \frac{G_1}{G_1 + G_2} = \frac{G_1}{G_1 + G_2}$$

$$S_{R_1}^{\omega_0} = -\frac{R_2}{R_1 + R_2}$$

**Note this is dependent upon the components as well !
Actually dependent upon component ratio!**

Theorem: If $f(x_1, \dots, x_m)$ can be expressed as $f = x_1^{\alpha_1} x_2^{\alpha_2} \dots x_m^{\alpha_m}$

where $\{\alpha_1, \alpha_2, \dots, \alpha_m\}$ are real numbers, then $S_{x_i}^f$ is not dependent upon any of the variables in the set $\{x_1, \dots, x_m\}$

Proof:

$$S_{x_i}^f = S_{x_i}^{X_i^{\alpha_i}}$$

$$S_{x_i}^f = \alpha_i$$

$$S_{x_i}^{X_i^{\alpha_i}} = \frac{\partial X_i^{\alpha_i}}{\partial x_i} \bullet \frac{x_i}{X_i^{\alpha_i}}$$

$$S_{x_i}^{X_i^{\alpha_i}} = \alpha_i X_i^{\alpha_i - 1} \bullet \frac{x_i}{X_i^{\alpha_i}}$$

It is often the case that functions of interest are of the form expressed in the hypothesis of the theorem, and in these cases the previous claim is correct

$$S_{x_i}^{X_i^{\alpha_i}} = \alpha_i$$

Theorem: If $f(x_1, \dots, x_m)$ can be expressed as $f = x_1^{\alpha_1} x_2^{\alpha_2} \dots x_m^{\alpha_m}$

where $\{\alpha_1, \alpha_2, \dots, \alpha_m\}$ are real numbers, then the sensitivity terms in

$$\frac{df}{f} = \sum_{i=1}^k \left(S_{x_i}^f \Big|_{\bar{X}_N} \bullet \frac{dx_i}{x_{iN}} \right)$$

are dependent only upon the circuit architecture and not dependent upon the components and the right terms are dependent only upon the components and not dependent upon the architecture

This observation is useful for comparing the performance of two or more circuits where the function f shares this property

Metrics for Comparing Circuits

Summed Sensitivity

$$\rho_S = \sum_{i=1}^m \mathbf{S}_{x_i}^f$$

Not very useful because sum can be small even when individual sensitivities are large

Schoeffler Sensitivity

$$\rho = \sum_{i=1}^m \left| \mathbf{S}_{x_i}^f \right|$$

Strictly heuristic but does differentiate circuits with low sensitivities from those with high sensitivities

Metrics for Comparing Circuits

$$\rho = \sum_{i=1}^m \left| \mathbf{S}_{x_i}^f \right|$$

Often will consider several distinct sensitivity functions to consider effects of different components

$$\rho_R = \sum_{\text{All resistors}} \left| \mathbf{S}_{R_i}^f \right|$$

$$\rho_C = \sum_{\text{All capacitors}} \left| \mathbf{S}_{C_i}^f \right|$$

$$\rho_{OA} = \sum_{\text{All op amps}} \left| \mathbf{S}_{\tau_i}^f \right|$$

Homogeneity (defn)

A function f is homogeneous of order m in the n variables $\{x_1, x_2, \dots, x_n\}$ if

$$f(\lambda x_1, \lambda x_2, \dots, \lambda x_n) = \lambda^m f(x_1, x_2, \dots, x_n)$$

Note: f may be comprised of more than n variables

Theorem: If a function f is homogeneous of order m in the n variables $\{x_1, x_2, \dots, x_n\}$ then

$$\sum_{i=1}^n S_{x_i}^f = m$$

Proof:

$$f(\lambda x_1, \lambda x_2, \dots, \lambda x_n) = \lambda^m f(x_1, x_2, \dots, x_n)$$

Differentiate WRT λ

$$\frac{\partial (f(\lambda x_1, \lambda x_2, \dots, \lambda x_n))}{\partial \lambda} = m \lambda^{m-1} f(x_1, x_2, \dots, x_n)$$
$$\frac{\partial f}{\partial \lambda x_1} x_1 + \frac{\partial f}{\partial \lambda x_2} x_2 + \dots + \frac{\partial f}{\partial \lambda x_n} x_n = m \lambda^{m-1} f(x_1, x_2, \dots, x_n)$$

$$\frac{\partial f}{\partial \lambda x_1} x_1 + \frac{\partial f}{\partial \lambda x_2} x_2 + \dots + \frac{\partial f}{\partial \lambda x_n} x_n = m \lambda^{m-1} f(x_1, x_2, \dots, x_n)$$

Simplify notation

$$\frac{\partial f}{\partial \lambda x_1} x_1 + \frac{\partial f}{\partial \lambda x_2} x_2 + \dots + \frac{\partial f}{\partial \lambda x_n} x_n = m \lambda^m f$$

Divide by f

$$\frac{\partial f}{\partial \lambda x_1} \frac{x_1}{f} + \frac{\partial f}{\partial \lambda x_2} \frac{x_2}{f} + \dots + \frac{\partial f}{\partial \lambda x_n} \frac{x_n}{f} = m \lambda^m$$

Since true for all λ , also true for $\lambda=1$, thus

$$\frac{\partial f}{\partial x_1} \frac{x_1}{f} + \frac{\partial f}{\partial x_2} \frac{x_2}{f} + \dots + \frac{\partial f}{\partial x_n} \frac{x_n}{f} = m$$

This can be expressed as

$$\sum_{i=1}^n S_{x_i}^f = m$$

Theorem: If a function f is homogeneous of order m in the n variables $\{x_1, x_2, \dots, x_n\}$ then

$$\sum_{i=1}^n S_{x_i}^f = m$$

$$f(\lambda x_1, \lambda x_2, \dots, \lambda x_n) = \lambda^m f(x_1, x_2, \dots, x_n)$$

The concept of homogeneity and this theorem were somewhat late to appear

Are there really any useful applications of this rather odd observation?



Stay Safe and Stay Healthy !

End of Lecture 20